

REVISITING SOME REGIONAL AMPHORA IMITATIONS DISCOVERED AT POPEȘTI FROM THE BUCHAREST MUNICIPALITY MUSEUM COLLECTION

Alina Streinu*

Key words: *non-epigraphical stamps, amphora imitations, local production.*
Cuvinte cheie: *ștampile anepigrafice, imitații amforice, producție locală.*

Rezumat: *Scopul acestui articol este de a relua discuția despre imitațiile locale ale amforelor Rhodiene și de Cos descoperite în timpul cercetărilor arheologice din dava de la Popești, aflate în colecția Muzeului Municipiului București. Ștampilele au făcut deja subiectul a numeroase discuții, însă producția amforelor și comerțul în care erau implicate într-o anumită arie geografică, încă ridică întrebări.*

Abstract: *The paper aims at reviewing some of the stamped handles of the local imitations of Rhodian and Koan amphorae discovered during the earlier excavations in the dava from Popești, currently in the Bucharest Municipality Museum. Even though the stamps have benefited from discussions, there are still questions as to the production centers of these imitations and the geographical area for the commerce with these products.*

Introduction

The fragments currently in the Bucharest Municipality Museum¹ were first registered in the inventory in 1957, thus they probably originate from excavations performed between 1954 and 1956 at Popești. The stamped amphorae fragments discovered were found in layers dating from the 2nd-1st centuries BC up to the beginning of the 1st century AD². Even though Rhodian imitations are the most numerous during the La Tène period, they were closely followed by imitations of vessels from other major centers starting with the 2nd century BC: Heraclea, Sinope, Thasos, Knidos, Chersonese and Kos³. The imitations of Rhodian amphorae are widely spread and find themselves among the most popular in several nearby Getae sites in southern Romania. Popești has been assumed to be a production center for some of these since most of the discoveries follows the shape and stamps of this Greek center⁴.

*Bucharest Municipality Museum.

¹In the Inventory of MMB, 18 such items are listed, all originating from Popești, but two of them have deteriorated stamps.

²Vulpe 1957, p. 227-245, 1957; Rosetti 1960, p. 396.

³Glodariu 1976, p. 33-35.

⁴Stoenști, Cetățeni, Crășani, Căscioarele, Zimnicea and Cozia, in Glodariu 1976, p. 133, 137-138.

The Hellenistic Rhodian amphora has a widely familiar shape mainly due to its angular handle, but starting with the 2nd century B.C. the angle tends to sharpen and the body of the vessel narrows⁵(Fig.1).The stamps on these amphorae carried the names of Rhodian eponyms starting with c. 270 BC up to c. 108 BC⁶. As for the chronology of the these transport vessels, G. Finkielsztejn's research on stamps established seven periods of production: period I, 304-235 BC; period II, 234-199; period III, 198-161; period IV, 160-148; period V, 145-108; period VI, 107-86; period VII, 85 to the age of Augustus⁷. When it comes to the morphology of the vessels, only two types were distinguished: type I comprising the long-necked amphorae from the late 4th to the first quarter of the 3rd century, and type II that emerged in the first third of the 3rd century.⁸ The Koan amphora has a slightly flaring rim and is distinguishable by its double barreled handle. Unlike the Rhodian amphorae, the Koan productions are rarely stamped and then, mainly on one of the handles, with the name or the symbol of the potter⁹.

Morphological features of the imitations

The local/regional Rhodian amphorae, just like the originals, have a rounded rim, with diameters spanning between 10 and 11cm, long cylindrical necks and angular handles with a circular section. Just like the originals, the imitations can be separated into two categories, with a rounded handle (Fig.1, Fig.2.4-5) and with a sharper handle (Fig.2.6, Fig.3-4). Even though the majority of the stamped fragments come from imitations of the Rhodian amphorae, another vessel from a different centre was attested here, namely from Kos, also bearing a stamp¹⁰. This amphora (Fig. 4.15) also has a flaring rim with a 12 cm diameter, straight neck and a double barrel handle. One other vessel stands out as it does not belong to any of the two already mentioned types. It is a small amphora, with a 5 cm rim diameter and two fragmentary handles with a rectangular section. The rim is vertical and also rectangular in section. Both handles are stamped with a rectangular cartouche with crossed lines, in a similar manner to the Rhodian amphorae (Fig.4.16).

The stamps on the indigenous imitations of the Greek transport amphora

The stamps have no writing, probably due to the fact that the locals were not familiar with the Greek language, but they did manage to copy most of the design. The most common are the stamps with horizontal grooves in a rectangular cartouche, a type common for the late 3rd century amphorae¹¹. Similar stamps were used on some of the imitations discovered in Rousse, with a close dating.¹² Another type involves the

⁵ Grace 1953, p. 116-131.

⁶ Conovici 2006, p. 104.

⁷ Finkielsztejn 1995, p. 276-296; 2001; Ariel, Finkielsztejn 2003, p. 139.

⁸ Monachov 2006, p. 71-72.

⁹ Johnsson 2004, p. 135.

¹⁰ Original Koan amphorae were also widespread in Popești, in Tudor 1967, p. 42; Canarache 1957, Fig.79.

¹¹ Grace 1953, Plate 42.II.

¹² Varbanov 2013, no.2230.

use of waves in one or two registries and considering the original stamps, they could represent a motif that replaced the lettering in the case of the imitations. The third type is made of the rectangular stamps with lines that cross in the middle, with the observation that in this case the motif has been used on other types of vessels such as the non-Rhodian fractional amphora (Fig.4.16, Inv.no. 15946/15949). This design also appears on the imitations discovered on the territory of Bulgaria¹³. The same motif with the crossed diagonal lines appears on a circular stamp, this time applied on a double barreled handle from a Koan amphora (Fig. 5.15 and Fig.6 Type 7). The fourth type consists of rectangular stamps with oblique lines, sometimes making it difficult to establish a pattern, but which can also stand as a replacing motif for the Greek script. A fifth type comprises the rectangular stamps with lines of small rectangles. The last type is the stamps with vegetal motifs, mainly representations of leaves (Fig. 6). Not included in this paper are the representations of human figures, of which two examples were discovered at Popești¹⁴.

The fabrics

The question that arises is which of these centers produced these amphorae. The answer could come from the fabric analysis of the materials from these sites. The fabrics of the examples in the Museum's collection¹⁵ show a color that ranges from red to yellowish, as a result of the firing degree. Due to the same firing technique, some of the examples show insufficient firing indicated by their grayish core (Fig. 7 no. 6, 9). The fabrics are compact, sometimes porous (no. 4, 5) or abrasive (no. 4, 11). All of the fragments show the presence of mica and white inclusions (calcareous or mineral) and some of the examples have reddish inclusions (probably iron oxides; no. 2, 3, 7, 10, 11, 13, 16). The presence of red inclusions in the fabric separated the vessels into two groups: A, with the inclusions (2, 3, 7, 10, 11, 13, 16) and B, without them (1, 4, 5, 6, 8, 9, 12, 14, 15), indicating the use of different clay sources by the same center, or suggesting the existence of a second production centre. However, this issue can only be settled by performing chemical analysis on the samples from all sites and identify possible clay sources. This would still not suffice to precisely identify the center, when no kiln was discovered, since it is plausible that there were commercial relations between the aforementioned Getae settlements and the amphorae filled probably with wine, were exchanged among them.

Discussions

In the West Pontic indigenous sites, the Rhodian amphora is the type mostly imitated, without having any clear indications of previous economic relations with the Greek world. In the second century B.C., however, there seems to have been a development in the relations between the local and the Greek communities, leading to a series of imitations, not only of vessels, but also of stamps. This phenomenon has a

¹³Varbanov 2013, no.2167; Lazarenkoetalii 2008, no. X08.

¹⁴Glodariu 1976, p. 134, nr.12/46-47; Dupont, Lungu 2010, Fig.8.

¹⁵ Fig.7. The numbers on the samples correspond to the number of the amphorae in the catalogue and the rest of the figures. For the color of the fabric *Munsell Soil Color Chart* was used.

double meaning. First, it can be related to the trade in the area and the prestige of the foreign products, in this case, wine. We already know from Strabo's work that the Getae grew vines and made wine, a trade that was ended by Burebista¹⁶, so it is conceivable that they imitated the most common amphorae present in the regional trade. A second explanation, or rather a possible aspect of the phenomenon, is seeing this type of products as a non-traditional imitation of a form related not to the utility of the vessel as a transport container for various products, but rather as a symbol of power, given the presence of the Greek amphorae in the elite burials¹⁷.

While no certain production area with pottery kilns was discovered, these amphorae should be considered as of regional production rather than local in relation to a particular site. This is suggested by the fact that their area of distribution is limited, so far, to a particular geographical area and these vessels were discovered in several sites. In the case of Popești, one point of interest for a potential amphora's production area was identified at Popești- Nucet, with the suggestion that the Kos imitations could have been made here, with no mention of the Rhodian ones¹⁸.

In the southern part of Romania, between the Carpathians and the Danube, several imported amphorae and imitations dated to the Iron Age were discovered in various sites¹⁹, with or without stamps, mostly from Rhodos or imitations of the vessels produced there (Fig.8). Among these sites, Cetatea Dâmboviței (Cetatea lui Negru Vodă) from Stoieniști, Argeș (Cetățeni²⁰), stands out when it comes to a local production of amphora imitations and the use of non-epigraphic stamps²¹. The significance of this site is indicated also by the similarities between the imitation produced here and the amphorae from Popești, both in terms of the amphora and stamp types used²². Very similar imitations were also produced south of the Danube, both in terms of the type of amphora and the stamps²³, but also by the Black Sea²⁴, dating from the end of the 3rd century-beginning of the 2nd.

The imitation of particular types of amphorae was quite common during the Antiquity, sometimes due to a colony's loyalty to the center, to commercial relations and trading routes²⁵ or simply due to fashion, although it is not unlikely that the same amphora type began to be produced simultaneously in more than one site, out of pure

¹⁶ Strabo, VII.3.11.

¹⁷ Lawall 2010, p. 55.

¹⁸ Vulpe, Gheorghită 1986, p. 43-51.

¹⁹ Spanțov, Greaca, Căscioarele, Tăricești (Co. Călărași), Tinosul, Gura Vișioarei, (Co. Prahova), Piscul Crășani (Co. Ialomița), Zimnicea, (Co. Teleorman); Poiana (Co. Galați) in Tudor 1967; Balotești (Co. Ilfov) in Țentea *et alii* 2010.

²⁰ Rosetti 1960, Fig.5 – D.V. Rosetti makes reference to the existence of non-epigraphical stamps of amphorae discovered at Stoieniști, but refers to their site of origin as Cetățeni. In the same publications he also offers drawings of non-epigraphic stamps from Popești.

²¹ Tudor 1967, p. 41.

²² Tudor 1967, Fig.9.

²³ Varbanov 2013, no.2167 and no.2230 in Rousse.

²⁴ Lazarenko *et alii* 2008, no. X08.

²⁵ For example, the Pistiros inscription mentions Thracian trade routes and economic privileges for the Greek traders – Graninger 2012.

coincidence²⁶. In the case of the copies from Popești, their production is probably the result of commercial relations with the Greek settlements placed on the coast of the Black Sea and to the predominance of the Rhodian amphorae in the region. It is also possible that the local/regional producers chose to imitate these particular vessels following a preference for the Rhodian wine while their vessels, with imitated stamps, stood as a guarantee for the quality of the product they carried. This could be one explanation why a vessel such as the fractional amphora (Fig. 5 no. 16), although not of Rhodian inspiration, carries stamps usually applied on Rhodian imitations. Considering that the imitation of Greek amphorae was also attested south of the Danube and by the Black Sea, on the present territory of Bulgaria, starting with the end of the 3rd century BC, the question arises whether the imitations north of the Danube, dated in contexts starting from the 2nd century, emerged under the influence from the south or the other way around. So far, very few amphorae imitations²⁷ were discovered south of the Danube and the hypothesis that the production emerged under the influence of the northern settlements still stands.

Catalogue

1. Inv.no.15958. Rim, neck and handle. The fabric is light red (2.5YR6/8). Contains mica, fine white and gray inclusions.
Rim \varnothing 11 cm, Hp.8.3 cm, handle \varnothing 3.7 cm.
The stamp is placed on the upper part of the handle, close to the neck. The stamp is rectangular, slightly rounded at one end; it measures 4.5 \times 1.7 cm and consists of six horizontal and two vertical grooves.
Reference: Glodariu 1976, Pl. XX.
2. Inv.no.15947. Rim, neck and handle. The fabric is reddish yellow (5YR6/8). Contains mica, fine white and red inclusions. Light yellowish surface.
Rim \varnothing 11 cm, Hp.6.9 cm, handle \varnothing 4.5 cm.
The stamp is fragmentary, rectangular with five horizontal grooves and one vertical. It is placed on the upper part of the handle, close to the neck and it measures 4.2 \times 1.8 cm.
Reference: Glodariu 1976, Pl. XX.
3. Inv.no.15957. Fragmentary neck and handle. The fabric is reddish yellow (5YR6/8). Contains mica, fine white and red inclusions.
Hp.27 cm, handle \varnothing 3.5 cm.
The stamp is placed on the upper part of the handle, close to the neck. It had a rectangular shape, measures 4.2 \times 1.4 cm and consists of five horizontal and one vertical groove.
Reference: Glodariu 1976, Pl. XX.

²⁶ Garlan 2000.

²⁷ Varbanov, 2011.

4. Inv.no.15942. The fabric is yellowish red (5YR5/8). Contains mica, fine white and red inclusions; porous and abrasive texture. Traces of secondary exposure to fire. Rim \varnothing 11 cm, Hp.8.2 cm, the handle is fragmentary.
The stamp is placed on the upper part of the handle, close to the neck. The stamp is rectangular, measures 4×1.5 cm and consists of four oblique lines, one vertical towards one end, and one oval node towards the same end.
Reference: Glodariu 1976, Pl. XX.
5. Inv.no.15960. Fragmentary handle. The fabric is yellowish red (5YR5/8) and dark greenish gray (Gley 1 4/1) at the core; porous texture. Contains mica, white inclusions.
Handle \varnothing 4.2 cm.
The stamp is also fragmentary, rectangular, poorly preserved, and consists of six oblique lines. It is placed on the upper part of the handle, close to the neck; it measures 4.1×1.7 cm.
6. Inv.no.15941. The fabric is reddish yellow (5YR6/8) with a reddish gray core (5YR5/1). Contains mica, fine white inclusions. Light yellowish surface.
Rim \varnothing 11 cm, Hp.37 cm, Handle \varnothing 3.7 cm.
The stamps are placed on the upper part of the handle, close to the neck. They are identical, rectangular, measuring 3×2.7 cm; they consist of two diagonal lines that cross in the middle and 2 nodes on each end.
Reference: similar stamps have been published by Glodariu 1976, Pl.XIX-XX.
7. Inv.no.15962. Fragmentary neck and handle. The fabric is yellowish red (5YR5/8). Contains mica, fine white and red inclusions. Light yellowish surface.
Handle \varnothing 3.2 cm.
The stamp is fragmentary and poorly preserved. Placed on the upper part of the handle, close to the neck. Has a rectangular shape and seems to depict vegetable motifs. It measures 4.1×1.9 cm.
Reference: similar stamps with vegetal motifs were published by Glodariu 1976, Pl. XIX-XX.
8. Inv.no.15948. Fragmentary neck and handle. The fabric is red (2.5YR4/8). Contains mica, fine white and gray inclusions. Light yellowish surface. The lower part of the handle seems to be have been polished in a straight direction.
Upper handle \varnothing 5.3×2.8 cm.
The stamp is placed on the upper part of the handle, close to the neck. It has a rectangular shape, measures 4.5×1.3 cm and entails three horizontal lines of small rectangular impressions separated by a central vertical groove.
Reference: Glodariu 1976, Pl. XX.

9. Inv.no.15959. Fragmentary neck and handle. The fabric is reddish yellow (5YR6/6). Contains mica, white inclusions. Traces of a brownish, diluted slip. Handle \varnothing 3.9 cm.
The stamp is placed on the upper part of the handle, close to the neck. It has a rectangular shape, measure 4.6 \times 1.7 cm and entails two diagonal lines that meet in the middle with a center vertical groove and a second groove at one end.
Reference: Glodariu 1976, Pl. XX.
10. Inv.no.15944. Fragmentary neck and handle. The fabric is reddish yellow (5YR6/8). Contains mica, white and red inclusions. Traces of a residue on the inner face.
Handle \varnothing 4.5 cm.
The stamp is placed on the upper part of the handle, close to the neck. It has a rectangular shape, measures 4.7 \times 1.8 cm and entails two registries of oblique lines separated by a horizontal groove.
Reference: Glodariu 1976, Pl. XX for other similar stamps.
11. Inv.no.15954. Fragmentary neck and handle. The fabric is reddish yellow (5YR6/6). Contains mica, white and red inclusions; slightly abrasive texture.
The stamp is placed on the upper part of the handle, close to the neck. It has a rectangular shape, measures 4 \times 1.5 cm and entails two registries of oblique lines and semi circles separated by a horizontal groove.
Reference: Glodariu 1976, Pl. XX for this stamp and other similar; Canarache 1957, Fig. 79.
12. Inv.no.15955. Fragmentary neck and handle. The fabric is light red (2.5YR6/8). Contains mica and fine white inclusions. Light yellowish surface and traces of a brownish, diluted slip.
The stamp is placed on the upper part of the handle, close to the neck. It has a rectangular shape, measures 3.4 \times 1.3 cm and entails three lines of small, rectangular impressions, one vertical groove towards one end separating the registry from a larger and rounder impression.
Reference: Glodariu 1976, Pl. XX for this stamp and other similar examples; Canarache 1957, Fig. 79.
13. Inv.no.15956. Fragmentary neck and handle. The fabric is reddish yellow (5YR6/8) to yellowish brown (10YR5/6). Contains rare mica and fine white and red inclusions. Traces of secondary exposure to fire.
Handle \varnothing 3.7 cm.
The stamp is placed on the upper part of the handle, close to the neck. It has a rectangular shape, measures 3.4 \times 1.3 cm and entails three lines of small, rectangular impressions, one vertical groove towards one end separating the registry from a larger and rounder impression.
Reference: Glodariu 1976, Pl. XIX-XX for the stamp and other similar examples.

- 14.** Inv.no.15945. Fragmentary neck and handle. The fabric is gray (Gley 1 4/N). Contains rare mica and fine white and rare larger inclusions (0.6 cm). Light yellowish surface.
Handle \varnothing 3.8 cm.
The stamp is placed on the upper part of the handle, close to the neck. It has a rectangular shape, measures 4.5 \times 1.4 cm and entails a series of oblique line in the shape of a wave.
Reference: Glodariu 1976, Pl. XX; Garlan 2000, fig. 41.
- 15.** Inv.no.15961. Rim, neck and fragmentary double barrel handle. The fabric is reddish yellow (5YR6/8). Contains fine white inclusions.
Rim \varnothing 12 cm, Hp. 6.3 cm, handle \varnothing 5.3 \times 2.5 cm.
The stamp is placed on the upper part of the handle, towards the neck. It has a circular shape, measures 1.6 cm in diameter and entails two diagonal lines that meet in the middle.
Reference: Glodariu 1976, Pl. XX for this stamp and other similar; Canarache 1957, Fig.79.
- 16.** Inv.no.15946/15949. Rim, neck and both handles. The fabric is yellowish red (5YR5/8), slightly abrasive. Contains mica, fine white, brownish and gray inclusions.
Rim \varnothing 5 cm, Hp.4.7 cm, handle \varnothing 2 \times 1.7 cm.
The stamp is placed on the upper part of the handle, close to the neck. It has a rectangular shape, measure 2.3 \times 1.6 and depicts two grooves towards each end and two diagonal lines that meet in the middle.
Reference: Glodariu 1976, Pl.XX.

Bibliography

- Ariel, Finkielsztejn 2003:** D.T.Ariel, G. Finkielsztejn, *Chapter 8. Amphora stamps and imported amphoras*, A. Kloner, *Maresha excavations Final report I: Subterranean complexes 21, 44, 70*, IAA Reports, 17, 2003, p. 137-151.
- Canarache 1957:** I. Canarache, *Importul amforelor ștampilate la Histria*, Editura Academiei Republicii Populare Romane, București, 1957.
- Conovici 2006:** N. Conovici, *The dynamics of Trade in Transport Amphoras*, V. Stolba, L. Hannestad (eds.), *Chronologies of the Black Sea Area in the period c.400-100 BC*, BSS 3, 2006, p. 97-117.
- Dupont, Lungu 2010:** P. Dupont, V. Lungu, *Synergia Pontica&Aegeo-Anatolica*, ed. Pax Aura Mundi, Galați, 2010, p. 227 – 239.
- Finkielsztejn 1995:** G. Finkielsztejn, *Chronologie basse de timbres amphoriques rhodiens et évaluation des exportations d'amphores*, ActaHyp 6, 1995, p. 279-96.

- Finkielsztejn 2001:** G. Finkielsztejn, *Politique et commerce à Rhodes au IIe s. a.C.: Le témoignage des exportations d'amphores*, A. Bresson, R. Descat (eds.), *Les cites d'Asie Mineure Occidentale au IIe Siècle a.C.*, Ausonius Publications, Études8, 2001, p. 181-196.
- Garlan 2000:** Y. Garlan, *Amphores et timbres amphoriques grecs. Entre erudition et idéologie*, Mémoires de l'Académie des Inscriptions et Belles-Lettres. Nouvelle Série, Tome XXI, *De Boccard*, Paris, 2000.
- Glodariu 1974:** I. Glodariu, *Relațiile comerciale ale Daciei cu lumea elenistică și romană*, Cluj-Napoca, 1974.
- Grace 1953:** V. Grace, *The eponym names on Rhodian amphora stamps*, *Hesperia*, 22, 1953, p. 116-131.
- Graninger 2012:** D. Graninger, *Documentary contexts for the "Pistiros Inscription"*, *Electrum*, vol.19, 2012, p. 99-110.
- Johnsson 2004:** H. Johnsson, *The export of Koan wine to the south-eastern Mediterranean area during the Hellenistic period*, K. Höghammar (ed.), *Boreas* 28. *The Hellenistic Polis of Kos. State, economy and culture*, Proceedings of an international seminar organized by the Department of Archaeology and Ancient History, Uppsala University, 11-13 May 2000, 2004, p. 133-151.
- Lawall 2010:** M. Lawall, *Imitative amphoras in the Greek world*, *Marburger Beiträge zur Antiken Handels, Wirtschafts und Sozialgeschichte*, Band 28, 2000, p. 45-88.
- Lazarenko et alii 2008:** I. Lazarenko, E. Mircheva, P. Georgiev, *Hellenistic sub-mound sepulture facility near the village of Bozhurets, district of Kavarna*, Proceedings The World of the Getae, Book XII, Rousse Regional Museum of History, 2008, p. 136-148.
- Monachov 2006:** S. Monachov, *Rhodian Amphoras: Developments in Form and Measurements*, V. Stolba, L. Hannestad (eds.), *Chronologies of the Black Sea Area in the period c.400-100 BC*, BSS, 3, 2006, p. 69-95.
- Rosetti 1960:** D. V. Rosetti, *Un deposit de unelte, câteva ștampile anepigrafice și o monedă din a doua epocă a fierului*, SCIV, 11, 2, 1960, p. 391-404.
- Strabo** *Geography*, Loeb Classical Library, 1924.
- Tudor 1967:** D. Tudor, *Răspândirea amforelor grecești ștampilate în Moldova, Muntenia și Oltenia*, ArhMold, V, 1967, p. 37-80.
- Țentea et alii 2010:** O. Țentea, S. Cleșiu, C. Borș, M. Florea, A. Rațiu, *Cercetări arheologice preventive în zona Balotești (Jud. Ilfov)*, CA, XVII, București, 2010, p. 177-224.
- Varbanov 2013:** V. Varbanov, *Anepigraphic amphorae stamps*, Sexaginta Prista, Tom 1, Rousse Regional Museum of History, 2013, p. 177-179.
- Varbanov 2011:** V. Varbanov, *Late Hellenistic Anepigraphic Amphora Stamps from Northeastern Bulgaria*, *Archaeologica Bulgarica*, XV, 1, 2011, p. 53-59.
- Vulpe 1957:** R. Vulpe, *Situl arheologic Popești*, MCA, III, 1957, p. 227-245.
- Vulpe, Gheorghiu 1986:** R. Vulpe, M. Gheorghiu, *Săpăturile arheologice din Stațiunea Getică de la Popești, com. Mihăilești, Jud. Giurgiu, 1980-1981 și 1983*, CA, 8, 1986, p. 43-52.

List of illustrations / Lista ilustrațiilor

Figure 1. Imitations of earlier Rhodian amphorae with rounded handles.

Figura 1. Imitații ale amforelor Rhodiene timpurii cu toarta rotunjită.

Figure 2. 4-5 Imitations of earlier Rhodian amphorae with rounded handles; 6 Imitations of later Rhodian amphorae with a sharper angle of the handle.

Figura 2. 4-5 Imitații ale amforelor Rhodiene timpurii cu toarta rotunjită; 6 Imitații ale amforelor Rhodiene târzii cu unghi mai ascuțit al toartei.

Figure 3. Imitations of later Rhodian amphorae with a sharper angle of the handle.

Figura 3. Imitații ale amforelor Rhodiene târzii cu unghi mai ascuțit al toartei.

Figure 4. Imitations of later Rhodian amphorae with a sharper angle of the handle.

Figura 4. Imitații ale amforelor Rhodiene târzii cu unghi mai ascuțit al toartei.

Figure 5. 15 Imitation of a double barrel Koan amphora; 16 Undetermined stamped amphora.

Figura 5. 15 Imitație a unei amfore de Kos cu toarta bifidă; 16 Amforă șampilată nedeterminată tipologic.

Figure 6. Types of non-epigraphic stamps.

Figura 6. Tipuri de ștampile anepigrafe.

Figure 7. Types of fabrics.

Figura 7. Tipuri de pastă.

Figure 8. Distribution of the imitated stamped amphorae (courtesy of Bogdan Șandric, National Institute of Heritage).

Figura 8. Distribuția imitațiilor de amfore șampilate (prin amabilitatea lui Bogdan Șandric, Institutul Național al Patrimoniului).

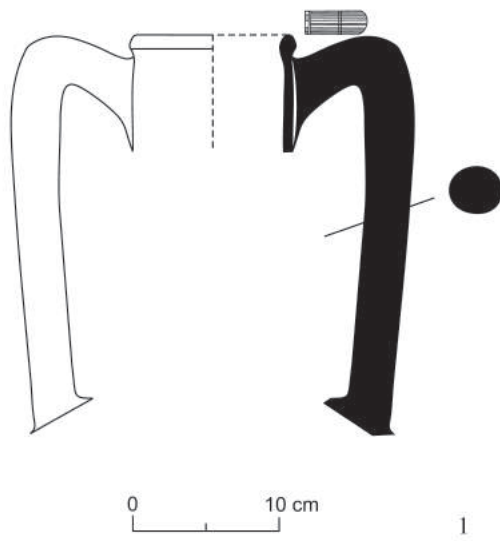

1

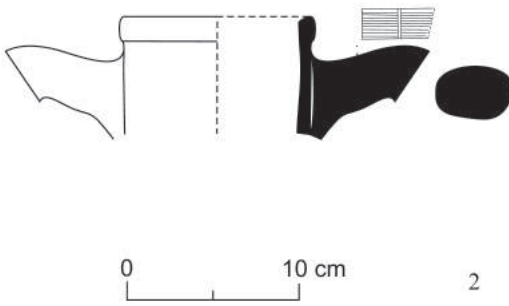

2



3



Fig. 1. Imitations of earlier Rhodian amphorae with rounded handles.

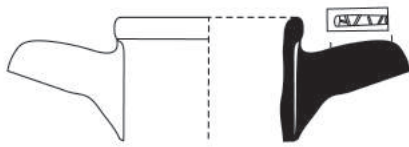

0 10 cm



4

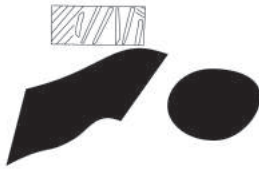

0 10 cm



5

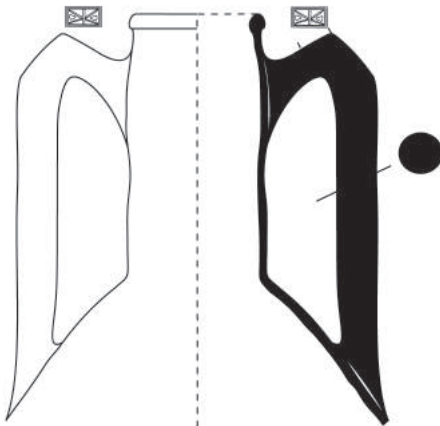

0 10 cm

6

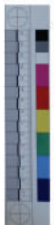
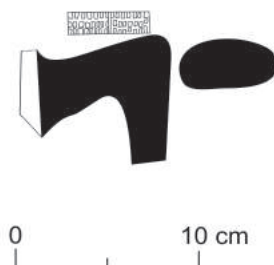

Fig. 2. 4-5. Imitations of earlier Rhodian amphorae with rounded handles;
6. Imitations of later Rhodian amphorae with a sharper angle of the handle.



7



8

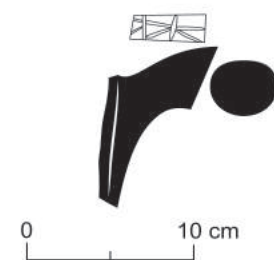

9

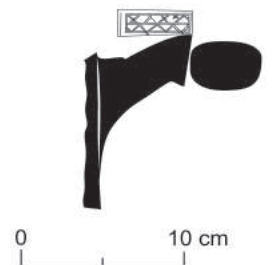
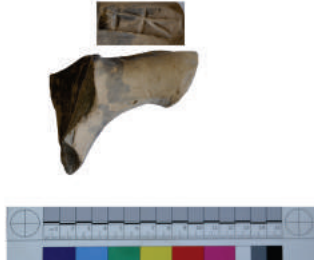

10



Fig. 3. Imitations of Later Rhodian amphorae with sharper handles.

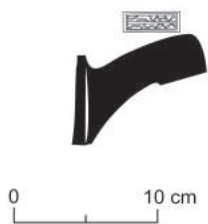

11

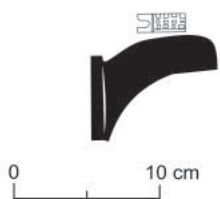

12

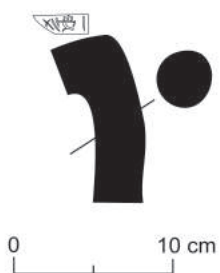

13

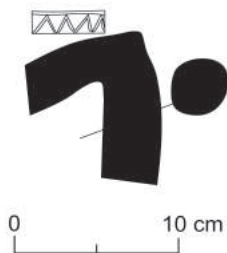

14



Fig. 4. Imitations of later Rhodian amphorae with sharper handles.

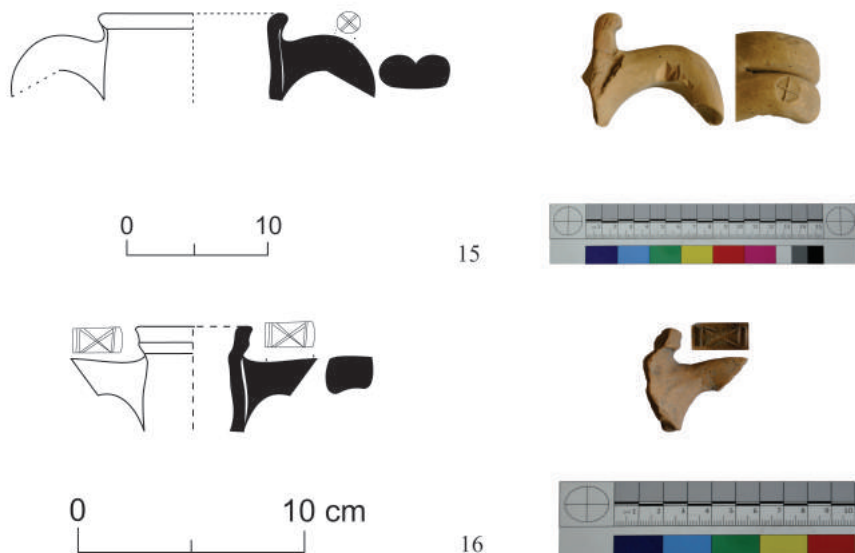

Fig. 5.15 - Imitation of a double barrel Koan amphora;
 16 - Undetermined stamped amphora.

Type 1			
Type 2			
Type 3			
Type 4			
Type 5			
Type 6			
Type 7			

Fig. 6. Types of non-epigraphic stamps.

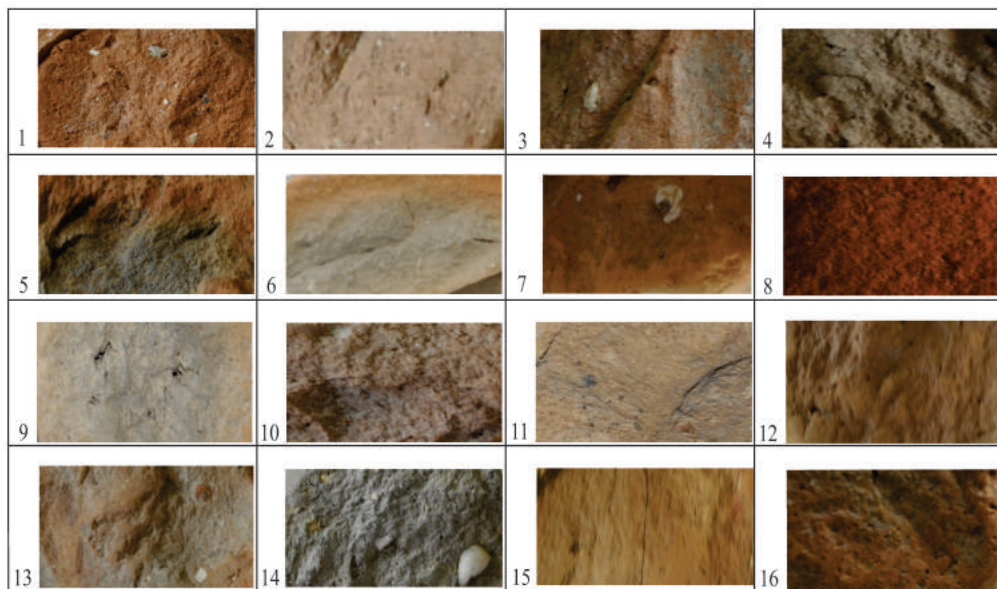

Fig. 7. Types of fabrics.

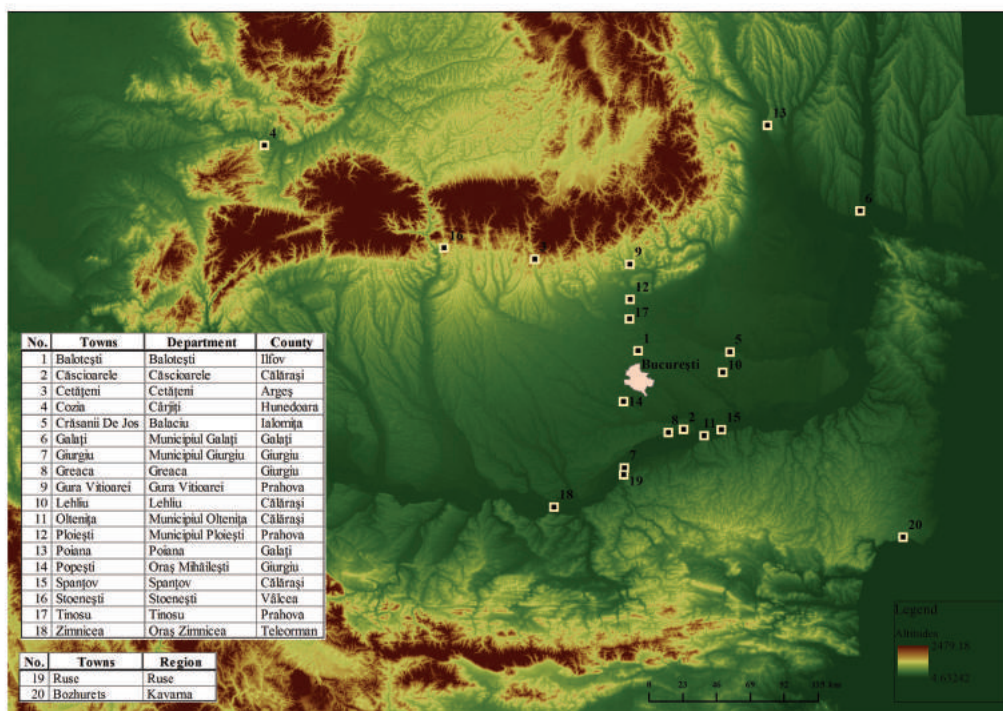

Fig. 8. Distribution of the imitated stamped amphorae (courtesy of Bogdan Șandric, INP).